

Digital Drum Owner's Manual

INFORMATION FOR YOUR SAFETY!

THE FCC REGULATION WARNING (for USA)

This equipment has been tested and found to comply with the limits for a Class B digital device, pursuant to Part 15 of the FCC Rules.

These limits are designed to provide reasonable protection against harmful interference in a residential installation. This equipment generates, uses, and can radiate radio frequency energy and, if not installed and used in accordance with the instructions, may cause harmful interference to radio communications. However, there is no guarantee that interference will not occur in a particular installation. If this equipment does cause harmful interference to radio or television reception, which can be determined by turning the equipment off and on, the user is encouraged to try to correct the interference by one or more of the following measures:

- Reorient or relocate the receiving antenna.
- Increase the separation between the equipment and receiver.
- Connect the equipment into an outlet on a circuit different from that to which the receiver is connected.
- Consult the dealer or an experienced radio/TV technician for help.

Unauthorized changes or modification to this system can void the user's authority to operate this equipment.

CAUTION

The normal function of the product may be disturbed by Strong Electro Magnetic Interference. If so, simply reset the product to resume normal operation by following the owner's manual. In case the function could not resume, please use the product in other location.

PRECAUTIONS

PLEASE READ CAREFULLY BEFORE PROCEEDING

Please keep this manual in a safe place for future reference.

Power Supply

Please connect the designated AC adaptor to an AC outlet of the correct voltage.

Do not connect it to an AC outlet of voltage other than that for which your instrument is intended.

Unplug the AC power adaptor when not using the instrument, or during electrical storms.

Connections

Before connecting the instrument to other devices, turn off the power to all units. This will help prevent malfunction and / or damage to other devices.

Location

Do not expose the instrument to the following conditions to avoid deformation, discoloration, or more serious damage:

- Direct sunlight
- Extreme temperature or humidity
- Excessive dusty or dirty location
- Strong vibrations or shocks
- Close to magnetic fields

Interference with other electrical devices

Radios and televisions placed nearby may experience reception interference. Operate this unit at a suitable distance from radios and televisions.

Cleaning

Clean only with a soft, dry cloth. Do not use paint thinners, solvents, cleaning fluids, or chemical-impregnated wiping cloths.

Handling

Do not apply excessive force to the switches or controls.

Do not let paper, metallic, or other objects into the instrument. If this happens, remove the electric plug from the outlet. Then have the instrument inspected by qualified service personnel.

Disconnect all cables before moving the instrument.

Contents

Panel Controls

Front Panel.....	4
Rear Panel.....	5
Side Panel.....	5

Setup

Connect the Pads and the Pedal.....	6
Connect a MIDI Device.....	7
Connect a Audio Equipment.....	7
Connect a CD player, etc.(Aux in jack).....	7
Connect Headphones.....	7
Connect the Power Supply Jack.....	7

Functions

Switch the Power ON.....	8
Set the Main Volume.....	8
Select a Drum Kit.....	8
Play with a Metronome.....	8

Play a Song

Select a Song.....	9
Listen to the Song.....	9
Adjust the Song's Volume.....	9
Adjust the Song's Tempo.....	9
Mute a Drum Part.....	10
Play with a Click Voice.....	10
Use the Lighting Guide Function.....	10

Create a User Drum Kit

Set a Drum Voice.....	11
Adjust the Volume of Pad.....	11
Adjust the Song Number of Pad Pattern Function.....	11
Save Your Drum Kit Voices.....	12

Setting

Adjust the Pad Sensitivity.....	13
Set the Rejection for Each Pad.....	13
Reverb.....	14
Tuning.....	14
Factory Set.....	14
ERP Function Instruction/ERP.....	14

Making the Settings for MIDI.....	15
--	-----------

Specifications.....	15
----------------------------	-----------

Appendix

Voice List.....	16
Preset Kit List.....	18
Song List.....	19
GM Drum Voice List.....	20
MIDI Implementation Chart.....	23

Panel Controls

Front Panel

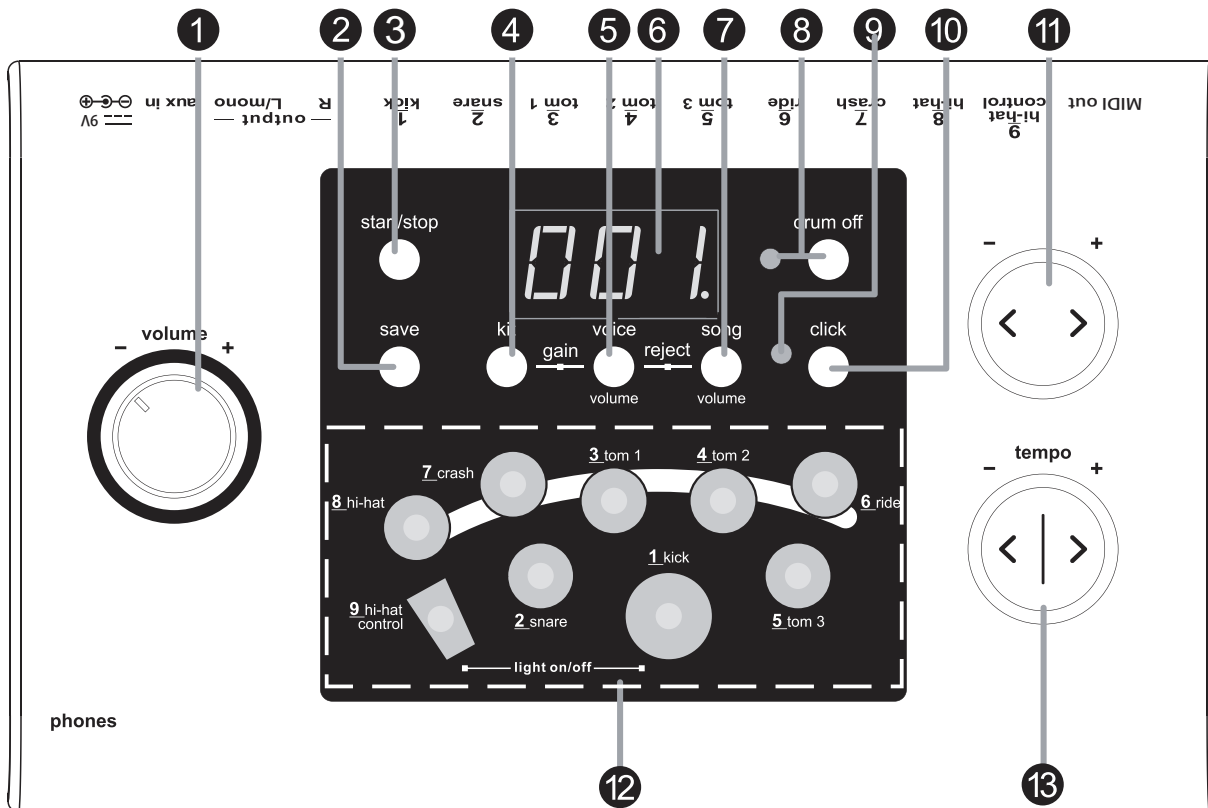

1. Volume knob

Control the volume of phone and line output. Turn it clockwise to increase the volume and anticlockwise to decrease it.

2. [save] button

Save current kit setting to a user kit.

3. [start/stop] button

Start or stop song playing.

4. [kit] button

Display the drum kit number or reverb setting.

5. [voice / volume] button

Display the voice number, volume value or pitch value.

6. 3-digit LED display

Display the parameters of current menu mode.

7. [song / volume] button

Display the song number or accompaniment volume value.

8. [drum off] button and indicator

This button is used to turn on or turn off the percussion of song.

9. Beat indicator

Beat of metronome or a song is playing

10. [click] button

Turn on or off the metronome.

11. [+] and [-] buttons

These buttons are used to change the setting number of kit, voice, song and adjust the Pad volume.

12. Pad select buttons and indicators

Select current pad and adjust the pad volume. When you press them, the corresponding indicator lights up.

13. [tempo - / +] buttons

Change current tempo.

Panel Controls

Rear Panel

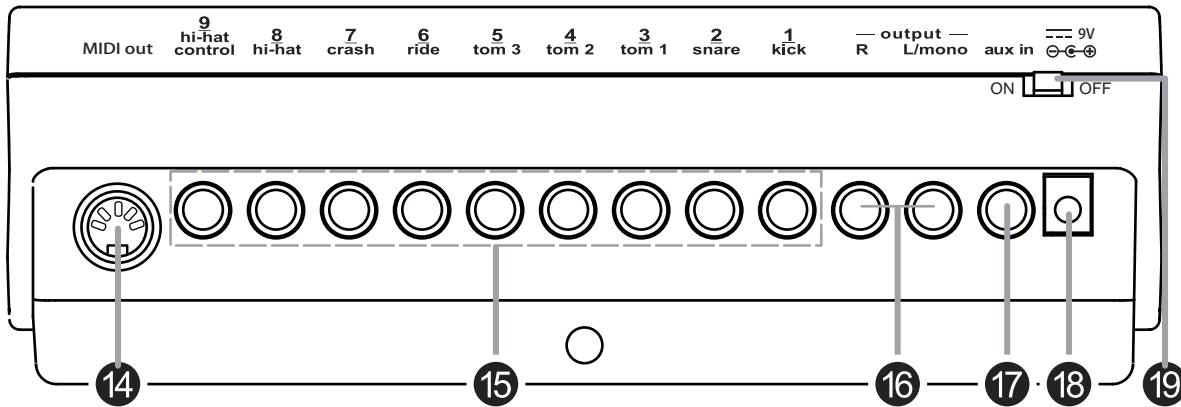

14. MIDI out jack

Connect with external sound module.

15. Trigger input jacks

Connect with pads, cymbals, hi-hat control, kick trigger.

16. Output jacks (R, L/mono)

Connect with the amplifier or audio system. For monaural output use the L/mono jack.

17. Aux.in jack

Connect with external sound source.

18. Power supply jack (DC in 9V)

Connect an AC adaptor to this jack.

19. Power switch

Turn the power on/off.

Side Panel

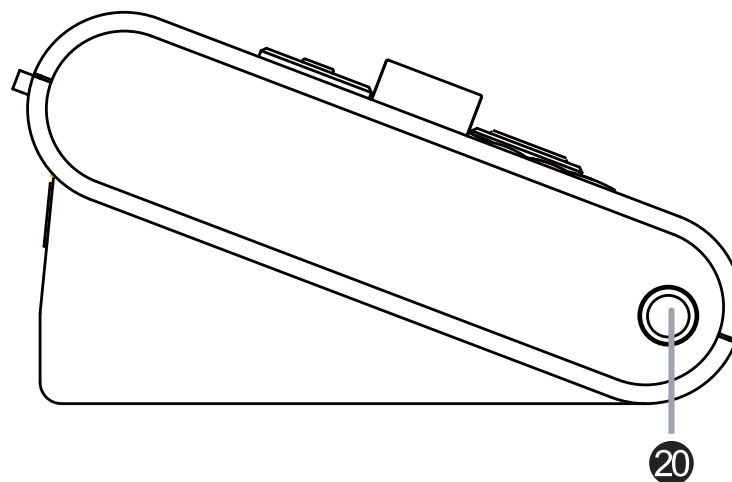

20. Phones jack

Connect with to a pair of stereo headphones to this jack. (Connect the headphones will not mute the output jacks.)

Setup

Caution!

To prevent electric shock and damage to the device, make sure the power is switched OFF on the drum and all related device before making any connection.

Connect the Pads and the Pedals

Using the provided cables, connect each Trigger input jack on the rear panel of the module, and make sure each pad is connected to its corresponding Trigger input jack.

Note:

1. The voice of hi-hat pad hitting is controlled by hi-hat pedal. Similar to a real drum kit, the hi-hat pad functions as an 'open hi-hat' when the pedal is stepped. When the pedal is released, it functions as a 'closed hi-hat'.
2. Choking (pinching) the cymbal's edge with the hand immediately after hitting the cymbal makes the sound stop. Both Ride and Crash cymbals have cymbal choke. But hi-hat don't have the cymbal choke. Choking the crash/ride edge with the hand immediately after hitting the crash/ride mutes the crash/ride sound.

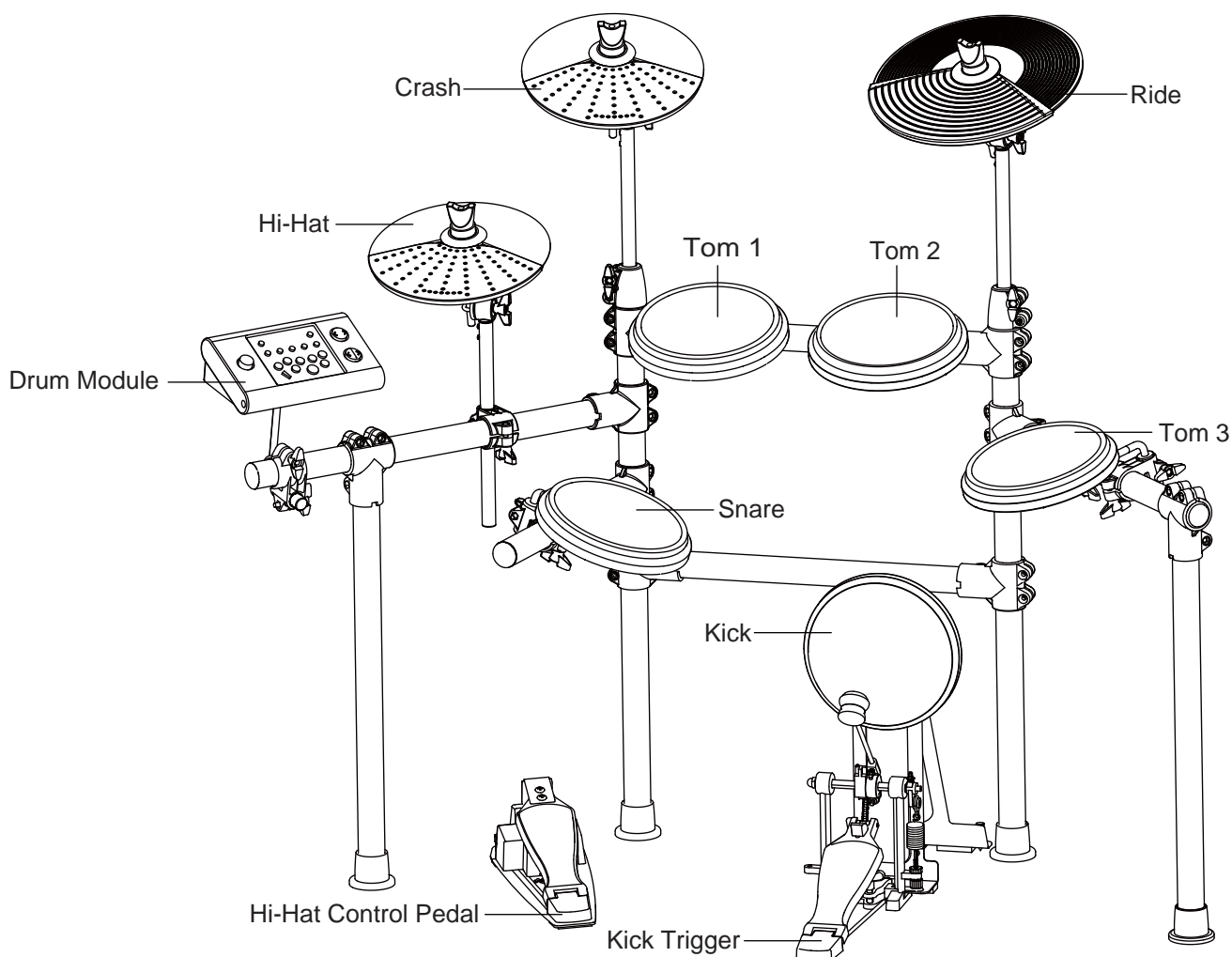

Connect a MIDI Device

This is for you want to use an external sound module or MIDI sequencer.

Transmit MIDI Data

1. Use a MIDI cable to connect the MIDI OUT jack on the drum module with the MIDI IN jack on the external MIDI device.
2. This drum will output all the MIDI codes generated by pads hitting or pedal stepping via the MIDI output connector. But clicking and the MIDI codes in songs are excluded.

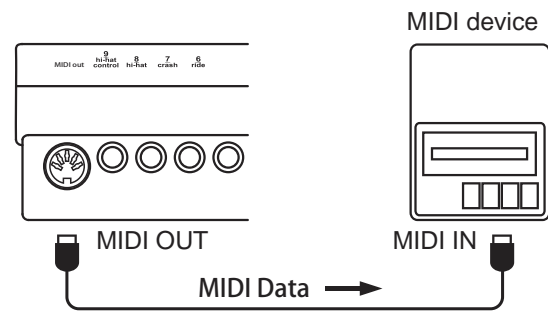

Connect a Audio Equipment

1. When you want to listen to the voices with an amplifier, connect amplifiers with the Output L/MONO and R jacks on the rear panel. (For monaural playback, use the L/MONO jack; for stereo playback, connect both L/MONO and R jacks.)
2. The volume is adjusted with the VOLUME knob.

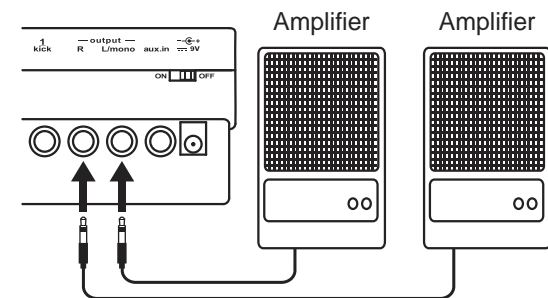

Connect a CD Player, etc.(Aux. In jac

1. The audio output of a CD player, or other audio source, to connect with the AUX IN jack on the rear panel can be mixed with the sound of the drum. This function is convenient that lets you play along with a favourite song.
2. The volume of the external signal is adjusted with the VOLUME knob.

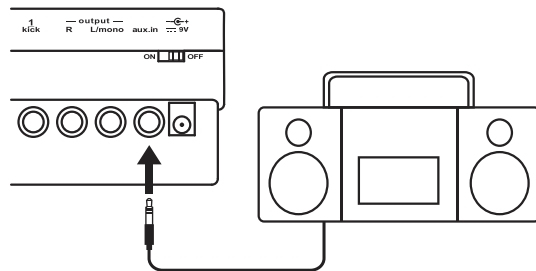

Connect Headphones

An optional set of stereo headphones can be connected with the PHONES jack located on the side of the drum module.

- * Adjust the volume to a comfortable level.

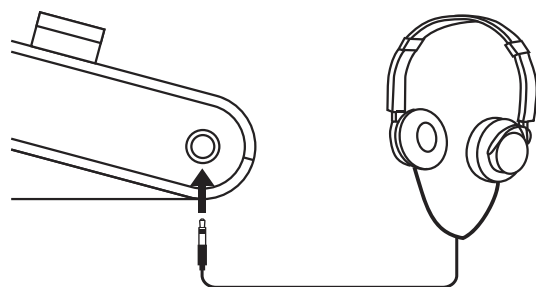

Connect the Power Supply Jack

Make sure the power is switched OFF and connect the power adaptor with the DC IN jack on the rear panel.

Note:

1. To protect the speakers, amplifier and the drum module from damage, rotate the volume knob to the minimum volume level before switching the power ON.
2. Make sure the power is switched OFF when connecting drum module with external devices.

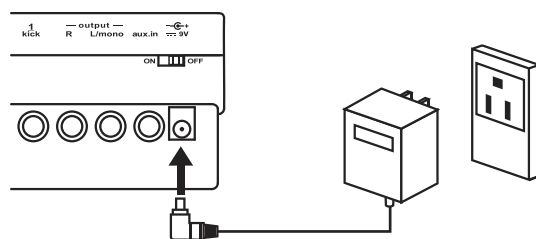

Functions

Switch the Power ON

After confirming all connection have been completed, rotate the volume knob to the left (minimum volume level) before switching the power on.

Set the power switch to "on" position to switch on the power. Display shows the song's number and its indicator lights up.

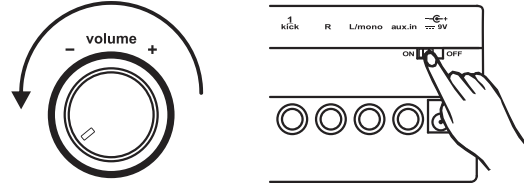

Set the Main Volume

While hitting a pad, gradually rotate the volume knob until a comfortable volume level is reached.



Select a Drum Kit

The unit comes with 35 (001-024) preset drum kits and 11 userkits (025-035).

1. Press [kit] button
The current kit number appears and the Kit indicator lights.
2. Press [+] or [-] buttons to select the drum kit number (001 - 024) you want to use.

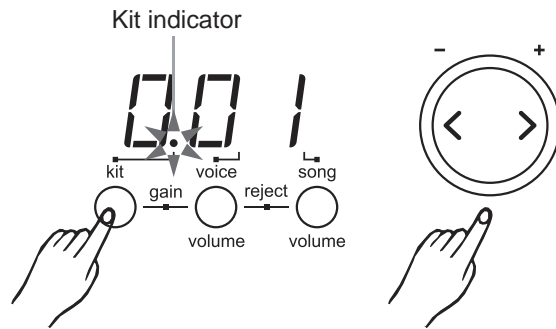

Play with a Metronome

1. Press the [click] button to start the metronome. The beat indicator is flashing and the click sound begins to play.
2. Press the [tempo +] or [tempo -] buttons to set the metronome beat.
3. Press the [click] button again to stop the metronome.

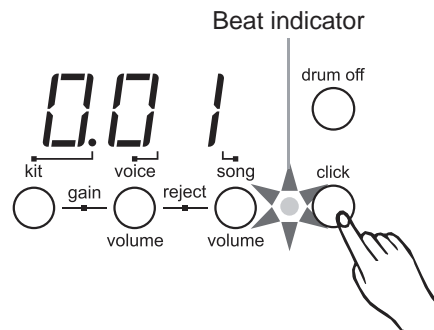

Adjust the Volume of the Click Sound

Hold down the [click] button and press the [+] or [-] buttons to adjust the volume of the click sound, the metronome automatically play.

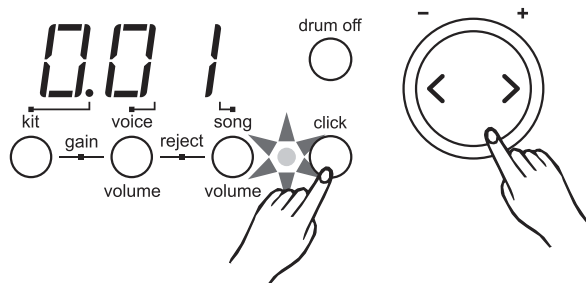

*Volume of the click sound will be reset to default once power is on.

Play a Song

Select a Song

This drum module has a total of 60 preset songs.

Note:

The preset song setting is 001 after you slide on power.

1. Press [song / volume] button.
The song indicator lights and the current song's number appears.
2. Press [+] or [-] buttons to select one of the song and listen to it.
Song numbers 001 - 060 are preset songs.

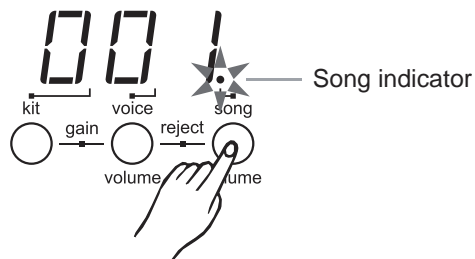

Listen to the Song

1. Press [start/stop] button and the beat indicator is flashing.
The song will start playback from the beginning.
 2. You can stop the song during playback by pressing the [start/stop] button.
- * The ASSIGN pad's indicator flashes at the first beat of each measure.

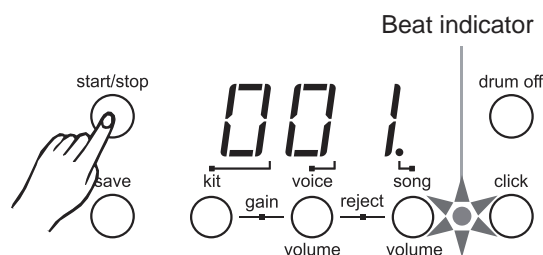

Note:

The ASSIGN pad's indicator can be lighted off by pressing both [hi-hat control] and [kick] buttons at the same time. You can also listen to the song by hitting the crash pad when the pad pattern function is not setting off.

Adjust the Song's Volume

1. Press the [song / volume] button to select the volume of song.
Display shows : " A XX". (XX = level value, 00 to 31)
2. Press [+] or [-] buttons to adjust the volume of song accompaniment.

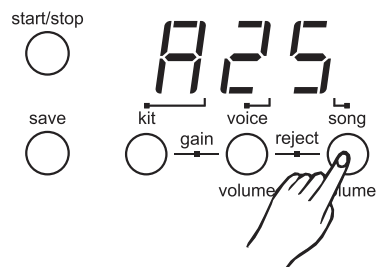

Adjust the Song's Tempo

1. Press the [tempo +] or [tempo -] buttons. Display shows the current tempo value.
 2. Press the [tempo +] or [tempo -] buttons to increase or decrease the tempo. (tempo value in the range of 30 to 280)
- * Holding down either a [tempo +] or [tempo -] buttons to change the setting in a high speed.
* Press [tempo +] and [tempo -] buttons at the same time to reset the tempo to default value.

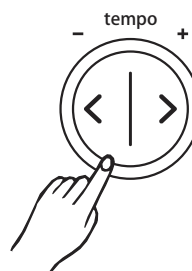

Note:

About 2 seconds after you stop pressing the [Tempo] button, display changes to show your selected song, voice or kit number instead of tempo value.

Play a Song

Mute a Drum Part

1. Press [drum off] button. The drum off indicator lights.
The drum mute function is active.
 2. Press [start/stop] button to playback the song. The drum part in the song will be muted.
 3. To cancel the drum mute function, press [drum off] button again.
The drum off indicator light goes off.
- * The drum mute function can be used during song playing.

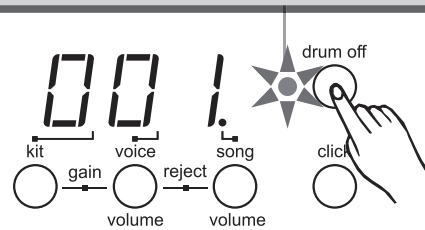

Play with a the Click Voice

1. Press the [click] button to start the metronome. It will be played with tempo.
2. Press the [click] button again to stop the metronome.

Note:

The click voice will not stop automatically once the song finished until you press the [click] button.

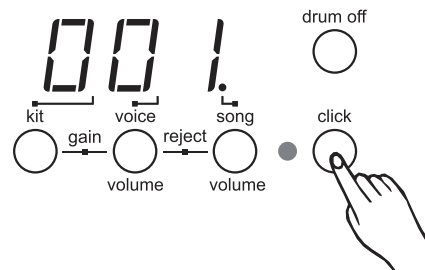

Use the Lighting Guide Function

The lighting guide function provides you a valuable lesson to practice or learn the drum kit with playing the preset song.

1. Select the song number you want to practice.
2. Press [drum off] button.
3. Press [start/stop] button to start song play.
4. Strike the pad in accordance with the lighting of pad's indicators or press the hi-hat pedal and kick the bass drum pad exactly when their indicators light.

* During song playing, you can change the Tempo(speed) to set your desired tempo.

* Press the [hi-hat control] + [kick] buttons to turn off all the pad's indicator. Press the [hi-hat control] + [kick] buttons again to turn on all the pad's indicator.

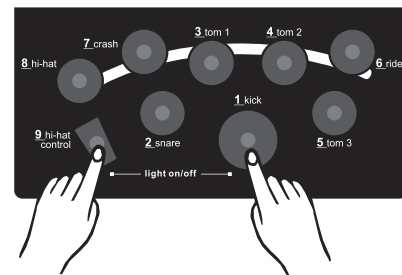

Create a User Drum Kit

Set a Drum Voice

The unit comes with 335 high quality percussion sounds that you can assign to any of the drum pad, 3 cymbals, hi-hat control and bass drum. This way you can create your own drum kit that consists of the voice you want. The kit number 025-035 is used for saving your own drum kit.

1. Press [voice] button.
The voice indicator lights and the display shows the voice number of this pad.
2. Press [pad] button or hit the pad you want to set.
The pad indicator light and display shows the current voice number of lighting pad.
3. Press [+] or [-] buttons to select the voice number you want to assign.
4. Repeat step 2 and 3 for to set the voice for another pad or bass drum.

Note:

Select the snare rim only through hitting the pad.

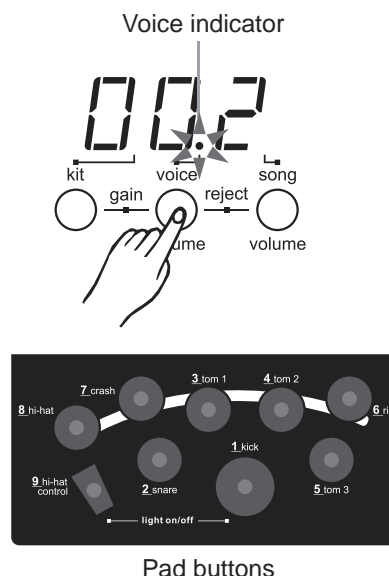

Pad buttons

Adjust the Volume of Pad

This unit allows you to adjust the volume of every voice in the kit that let you control the individual level (volume) of the pads or bass drum.

1. Press the [voice / volume] button to select the volume level setting display shows : " L XX".
(XX = level value, 00 to 31)
The pad button indicator lights and display shows the current volume level of lighting pad.
2. Press the [PAD] button or hit the percussion pad you want to adjust.
3. Press the [+] or [-] buttons to increase or decrease the volume.
While you are adjusting, hit the corresponding pad and listen carefully the sound level until reaching the level you want.
4. Repeat step 2 and 3 to adjust the volume of other pad voices.

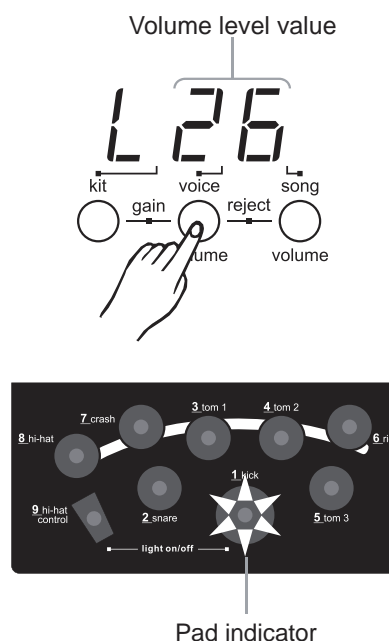

Pad indicator

Adjust the Song Number of Pad Pattern Function

The unit allows you to adjust the song number of pad pattern function in the kit that let you set the number of playing song when hitting the crash pad.

1. Press the [voice/volume] button to select the pad pattern setting display shows "OFF" or S XX".
(XX = level value, 1 to 60, OFF means closing this function and other option means setting the corresponding song number)
2. Press the [+] or [-] buttons to increase or decrease the song number.
While you are adjusting, hit the crash pad and listen the song until reaching the you want song. Hit again, stop the song.

Create a User Drum Kit

Save Your Drum Kit Voices

Once completing to your own drum kit, you have to savethem in the unit; otherwise your drum kit will be erased whenyou turn off the unit.

1. Press [save] button.
The kit number 025 appears and is flashing.
2. Press [+] or [-] buttons to set the kit number (025-035) for saving your drum kit.
3. Press [save] button again. The flashing kit number stops.

Note:

To cancel the save operation, press the [voice] button. If there is a fault, the display will show "Err".

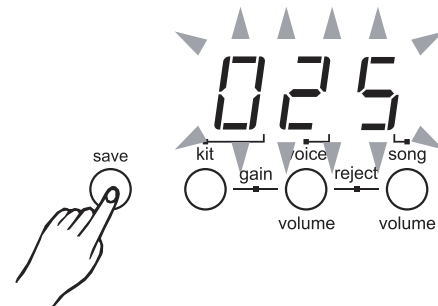

Setting

Adjust the Pad Sensitivity

You can adjust the sensitivity(gain) of the inputs from pads.

1. Hold down [kit] and press [voice / volume] buttons.
Display shows: "EXX", the pad sensitivity value is indicated.
(XX=gain level value, 00 to 15.)
2. Press [pad] button or hit the pad you want to set.
The pad indicator light.
3. Press [+] or [-] buttons to adjust the sensitivity of pads.
Range : 00-15
Large values will produce a high sensitivity even if the pad is hit softly. Lower values will producing a low sensitivity even if the pad is hit forcefully.
4. Repeat step 2 and 3 for to set the voice for another pad or bass drum.

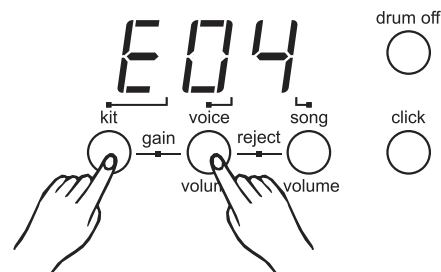

Note:

1. After adjusting the sensitivity value, you can save them into built-in memory. In the sensitivity mode, the sensitivity value is displayed, press [save] button and the sensitivity value will be saved, and then return to previous display.
2. The drum remains untouched for 10 seconds, the LED will return to previous display.
3. If turn off the power without save, you will lose the changes you have just made.

Set the Rejection for Each Pad

Prevents crosstalk caused by pads or drums connected to other inputs. Events triggered by other pads that are of a lower input value than what is set here will not be delivered for a set length of time.

1. Hold down [voice / volume] and press [song / volume] buttons.
Display shows: "JXX", the rejection value is indicated.
(XX=rejection level value, 00 to 15.)
2. Press [pad] button or hit the pad you want to set.
The pad indicator light.
3. Press [+] or [-] buttons to adjust the sensitivity of pads.
Range : 00(no rejection)-15
4. Repeat step 2 and 3 for to set the voice for another pad or bass drum.

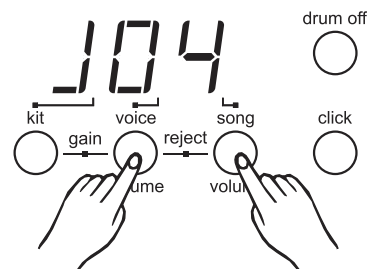

Note:

1. After adjusting the rejection value, you can save them into built-in memory. In the rejection mode, the rejection value is displayed, press [save] button and the rejection value will be saved, and then return to previous display.
2. The drum remains untouched for 10 seconds, the LED will return to previous display.
3. If turn off the power without save, you will lose the changes you have just made.

Setting

Reverb

This function sets the reverb effect of the drum.

1. In " kit mode", press the [kit] button, display shows the current reverb setting.

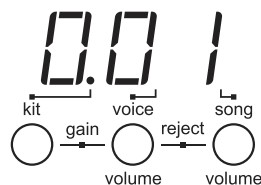

2. Press [+] or [-] buttons to turn on or turn off the reverb.

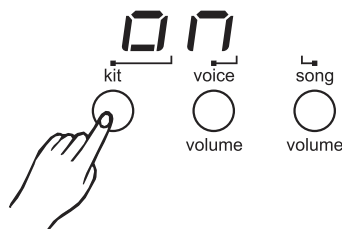

Tuning

This function sets the pitch of each drum pad voice.

1. Press the [voice / volume] button to select the pitch setting display shows : " P XX". (XX = value, 00 to 15)

The pad button indicator lights and display shows the current pitch setting of lighting pad.

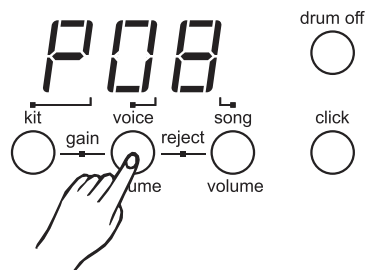

2. Press the [PAD] button or kit the percussion pad you want to adjust.

3. Press the [+] or [-] buttons to set the pitch you want.

4. Repeat step 2 and 3 to set the pitch of other pad voice.

Factory Reset

This drum module will reset its to initial settings. Beware all the data will be lost.

1. Turn the power off.

2. Turn on the power while holding the [tempo -] and [tempo +] buttons.



ERP Function Instruction/ERP

In order to save energy, we have designed the "Automatic shutdown" function for the drum module. With this function, the drum module will shutdown automatically when you have left it idle for more than 30 (default) minutes.

If you don't need this feature, just press and hold the [START/STOP] button then turn the drum module on. You will also see the 3-digit-LED temporarily displaying "PoF" for 3 seconds before entering the main menu which indicates that the "Automatic shutdown" function is turned off.



Making the Settings for MIDI

About MIDI

MIDI (Musical Instrument Digital Interface) is a standard that allows performance data and other information to be exchanged among electronic musical instruments and computers.

MIDI Connection

MIDI OUT: This terminal transmits data from the digital drum to other MIDI devices.

Connecting with an External Sound Device

The digital drum transmission channel for the drum kit is fixed to Channel 10. It will output MIDI data generated by the triggers when hitting the pads or stepping on the Hi-Hat control pedal (Note ON/OFF, and Foot messages). Song playback data and metronome notes are not transmitted.

MIDI Note Number to be Transmitted/Received by Each Pad

Each drum kit can have it's own set of MIDI note to be transmitted/received by each pad, useful for advanced purpose.

Trigger	MIDI Note	Trigger	MIDI Note	Trigger	MIDI Note	Trigger	MIDI Note
Kick	36	Tom1	48	Ride	51	Hi-hat C	42
Snare	38	Tom2	45	Crash	49	Hi-hat P	44
Snare rim	40	Tom3	43	Hi-hat O	46	Splash	21

Note:

For more information on received MIDI messages, refer to MIDI implementation chart.

Specifications

Drum Pad:

4 drum pads , 3 cymbal pads ,1 hi-hat control pedal , 1 kick trigger

Voices:

335voices

Drum Kits:

24 preset kits, 11 user kits

Song:

60 preset songs

Controls:

POWER SWITCH, START/STOP, SAVE, KIT, VOICE/VOLUME,SONG/VOLUME, DRUM OFF, CLICK, HI-HAT, CRASH, RIDE,HI-HAT CONTROL, SNARE, TOM 1, TOM 2, TOM3, KICK,VOLUME, + / -, TEMPO + / -

Display:

LED display

Connections:

MIDI OUT, Hi-hat control, Hi-hat, Crash, Ride, Snare, Tom 1, Tom 2, Tom 3, Kick, Output (R & L/MONO), Aux in

Power Supply:

AC adaptor (DC 9V)

Voice List

No.	Name
Kick	
1	Standard Kick 1
2	Standard Kick 2
3	Classic Kick 1
4	Classic Kick 2
5	Rock Kick 1
6	Rock Kick 2
7	Rock Kick 3
8	Room Kick 1
9	Room Kick 2
10	Jazz Kick 1
11	Jazz Kick 2
12	Big Band Kick 1
13	Big Band Kick 2
14	Camco Kick 1
15	Camco Kick 2
16	Funk Kick 1
17	Funk Kick 2
18	Funk Kick 3
19	HipHop Kick 1
20	HipHop Kick 2
21	HipHop Kick 3
22	HipHop Kick 4
23	1969 Kick
24	1971 Kick
25	1976 Kick
26	Power Kick
27	R&B Kick
28	Voice Kick
29	Acoustic Kick
30	Orchestra Kick
31	House Kick 1
32	House Kick 2
33	House Kick 3
34	House Kick 4
35	Step Kick
36	Teckno Kick
37	Drum & Bass Kick
38	Junkyard Kick
39	Noise Kick
40	Industry Kick
41	Lowfi Kick
42	Disco Kick
43	808 Kick
44	909 Kick
45	Electronic Kick 1
46	Electronic Kick 2
47	Electronic Kick 3
48	Electronic Kick 4
49	Electronic Kick 5
50	Electronic Kick 6
51	Electronic Kick 7
Snare	
52	Standard Snare
53	Standard Snare Rim
54	Classic Snare 1
55	Classic Snare Rim 1

56	Classic Snare 2
57	Classic Snare Rim 2
58	Acoustic Snare
59	Acoustic Snare Rim
60	Rock Snare 1
61	Rock Snare Rim 1
62	Rock Snare 2
63	Rock Snare 3
64	Room Snare 1
65	Room Snare 2
66	Room Snare 3
67	Steel Snare
68	Steel Snare Rim
69	Jazz Snare 1
70	Jazz Snare Rim 1
71	Jazz Snare 2
72	Jazz Snare Rim 2
73	Jazz Latin Snare
74	Big Band Snare
75	Camco Snare
76	Camco Snare Rim
77	Brush Snare 1
78	Brush Snare 2
79	Brush Snare Rim
80	Funk Snare
81	Funk Stick
82	Funk Band Snare 1
83	Funk Band Snare 2
84	Funk Band Snare Stick
85	Fusion Snare
86	Fusion Snare Stick
87	Snare Stick
88	Power Snare
89	HipHop Snare 1
90	HipHop Snare 2
91	1969 Snare
92	1969 Snare Rim
93	1971 Snare
94	1971 Snare Rim
95	1976 Snare
96	1976 Snare Rim
97	House Snare 1
98	House Snare 2
99	House Snare 3
100	Teckno Snare 1
101	Teckno Snare 2
102	808 Snare
103	909 Snare
104	Drum & Bass Snare 1
105	Drum & Bass Snare 2
106	TR606 Snare
107	Electronic Snare 1
108	Electronic Snare 2
109	Electronic Snare 3
110	Electronic Snare 4
111	Electronic Snare 5
112	Electronic Snare 6

113	Electronic Snare 7
114	Electronic Snare 8
Tom	
115	Classic Tom 1
116	Classic Tom 2
117	Classic Tom 3
118	Classic Tom 4
119	Classic Tom 5
120	Classic Tom 6
121	Standard Tom 1
122	Standard Tom 2
123	Standard Tom 3
124	Standard Tom 4
125	Standard Tom 5
126	Standard Tom 6
127	Camco Tom 1
128	Camco Tom 2
129	Camco Tom 3
130	Camco Tom 4
131	Camco Tom 5
132	Camco Tom 6
133	Rock Tom 1
134	Rock Tom 2
135	Rock Tom 3
136	Rock Tom 4
137	Rock Tom 5
138	Rock Tom 6
139	Room Tom 1
140	Room Tom 2
141	Room Tom 3
142	Room Tom 4
143	Room Tom 5
144	Room Tom 6
145	Funk Tom 1
146	Funk Tom 2
147	Funk Tom 3
148	Funk Tom 4
149	Funk Tom 5
150	Funk Tom 6
151	Fusion Tom 1
152	Fusion Tom 2
153	Fusion Tom 3
154	Fusion Tom 4
155	Fusion Tom 5
156	Fusion Tom 6
157	1969 Tom 1
158	1969 Tom 2
159	1969 Tom 3
160	1969 Tom 4
161	1971 Tom 1
162	1971 Tom 2
163	1971 Tom 3
164	1971 Tom 4
165	1976 Tom 1
166	1976 Tom 2
167	1976 Tom 3
168	1976 Tom 4

Voice List

169	HipHop Tom 1
170	HipHop Tom 2
171	HipHop Tom 3
172	HipHop Tom 4
173	HipHop Tom 5
174	HipHop Tom 6
175	Jazz Tom 1
176	Jazz Tom 2
177	Jazz Tom 3
178	Jazz Tom 4
179	Jazz Tom 5
180	Jazz Tom 6
181	Brush Tom 1
182	Brush Tom 2
183	Brush Tom 3
184	Brush Tom 4
185	Brush Tom 5
186	Brush Tom 6
187	Timpani 1
188	Timpani 2
189	Timpani 3
190	Timpani 4
191	TR606 Tom 1
192	TR606 Tom 2
193	TR606 Tom 3
194	TR606 Tom 4
195	TR606 Tom 5
196	TR606 Tom 6
197	808 Tom 1
198	808 Tom 2
199	808 Tom 3
200	808 Tom 4
201	808 Tom 5
202	808 Tom 6
203	Electronic Tom 1
204	Electronic Tom 2
205	Electronic Tom 3
206	Electronic Tom 4
207	Electronic Tom 5
208	Electronic Tom 6
209	909 Tom 1
210	909 Tom 2
211	909 Tom 3
212	909 Tom 4
Ride	
213	Classic Ride
214	Acoustic Ride
215	Standard 22" Ride
216	Brush Ride
217	Rock Ride
218	Clean Pop Ride
219	Flat Ride
220	60's Ride
221	808 Ride
Crash	
222	Classic Crash 1
223	Classic Crash 2

224	Standard Crash 1
225	Standard Crash 2
226	Standard Crash 3
227	Rock Crash 1
228	Rock Crash 2
229	Splash
230	Brush Crash
231	China
232	Orchestra Crash
233	HipHop Crash
234	808 Crash
235	606 Crash
236	Electronic Crash
Hi-Hat	
237	Standard Hi-hat Open
238	Pop Hi-hat Open
239	Rock Hi-hat Open
240	Jazz Hi-hat Open
241	Electronic Hi-hat Open
242	808 Hi-hat Open
243	House Hi-hat Open
244	Standard Half Open
245	Pop Half Open
246	Rock Half Open
247	Jazz Half Open
248	Standard Hi-hat Close
249	Pop Hi-hat Close
250	Rock Hi-hat Close
251	Jazz Hi-hat Close
252	Electronic Hi-hat Close
253	808 Hi-hat Close
254	House Hi-hat Close
255	Standard Hi-hat Pedal
256	Pop Hi-hat Pedal
257	Rock Hi-hat Pedal
258	Jazz Hi-hat Pedal
259	Electronic Hi-hat Pedal
260	808 Hi-hat Pedal
261	House Hi-hat Pedal
262	Standard Hi-hat Splash
263	Rock Hi-hat Splash
Percussion	
264	Metronome Bell
265	Metronome Click
266	Scratch
267	Scratch Push
268	DJ FX
269	High Q Zap
270	Ding Bell
271	Finger Snaps
272	Standard Clap
273	Vibraslap
274	Agogo High
275	Agogo Low
276	Bell Tree
277	Bongo High
278	Shaker

279	Conga Slap High
280	Conga Slap Mid
281	Conga Low
282	Conga Slap
283	Cowbell
284	Timbale High
285	Timbale Low
286	Timpani High
287	Timpani Low
288	Open Tabla High
289	Slap Tabla
290	Mute Slap Tabla
291	Cabasa
292	Maracas
293	Short Whistle
294	Short Guiro
295	Long Guiro
296	Claves
297	Wood Block
298	Muted Cuica
299	Open Cuica
300	Muted Triangle
301	Open Triangle
302	Sleigh Bells
303	Wind Chimes
304	Castanets
305	Muted Surdo
306	Open Surdo
307	Lotus Drum
308	Cowbell 1
309	Cowbell 2
310	Cowbell 3
311	Cowbell 4
312	Cowbell 5
313	Cowbell 6
314	Tabla 1
315	Tabla 2
316	Tabla 3
317	Tabla 4
318	Tabla 5
319	DJ 1
320	DJ 2
321	DJ 3
322	DJ 4
323	DJ 5
324	DJ 6
325	DJ 7
326	DJ 8
327	DJ 9
328	DJ 10
HI-HAT COMBINATIONS	
1	Standard
2	Pop
3	Rock
4	Jazz
5	Electronic
6	808
7	House

Preset Kit List

No.	Name
Acoustic	
1	Acoustic
2	Standard 1
3	Standard 2
4	Funk 1
5	Funk 2
6	Fusion
7	Camco
8	Brush
9	Room
10	Rock
11	Pop Rock
12	Jazz
13	Jazz Brush
14	Timpani
15	Songo
16	1971's
17	Latin
Electronic	
18	Disco
19	TR606
20	909
21	HipHop
22	Electronic 1
23	Electronic 2
24	Teckno 1
User	
25	Acoustic
26	Standard 1
27	Standard 2
28	Funk 1
29	Funk 2
30	Fusion
31	Camco
32	Brush
33	Room
34	Rock
35	Pop Rock

Song List

No.	Name	LCD Name
1	Drum Intro	DrumInt
2	Drum Main A	Drum A
3	Drum Main B	Drum B
4	Electronic&Funk	Blues&Fk
5	Ballad1	Ballad1
6	Fusion1	Fusion1
7	Dance1	Dance1
8	BigBand1	BigBand1
9	Funk1	Funk1
10	Big Band2	BigBand2
11	Funk2	Funk2
12	Pop Funk1	PopFunk1
13	Fusion2	Fusion2
14	Funk3	Funk3
15	Fusion3	Fusion3
16	Funk4	Funk4
17	Fusion4	Fusion4
18	Pop Funk2	PopFunk2
19	R&B	R&B
20	Drum N'Bass1	D n'B1
21	Break Beat	Break Bt
22	Dance2	Dance2
23	Drum n'Bass2	D N'B2
24	Latin Dance1	Ltin Dan1
25	Latin Dance2	Ltin Dan2
26	Swing1	Swing1
27	Latin Jazz2	Ltin jz2
28	Big Band3	Bigband3
29	3/4 Jazz	3/4 Jazz
30	Jazz1	Jazz1
31	Latin Jazz3	Ltin Jz3
32	Swing2	Swing2
33	6/8Ballad	6/8Ballid
34	Pop Ballad	Pop Bald
35	Pop Bossa	Pop Bosa
36	16Beat Pop	16Bt Pop
37	Pop Shuffle	Pop Shuf
38	60'sPop	60'sPop
39	Samba1	Samba1
40	Latin Pop1	Ltin Pop1
41	Mambo	Mambo
42	Latin Rock1	Ltin rk1
43	Latin Pop2	Ltin Pop2
44	Guitar Bossa	Gtr Bosa
45	Country Blues	Couty Bl
46	ClassicRock	ClasicRk
47	Reggae1	Reggae1
48	60's Rock	60's Rock
49	Blues	Blues
50	World1	World1
51	World2	World2
52	Latin	Latin
53	Bossa	Bossa
54	Samba2	Samba2

No.	Name	LCD Name
55	3/4Pop	Jazz2
56	Pop	Reggae2
57	Jazz2	Reggae3
58	Reggae2	Ltin Rk2
59	Reggae3	3/4Pop
60	Latin Rock2	Pop

GM Drum Voice List

	Standard 1 (bank 0)	Standard 2 (bank 4)	Room (bank 8)	Rock (bank 16)
27 – D#1	High Q	<-	<-	<-
28 – E1	Slap	<-	<-	<-
29 – F1	Scratch Push	<-	<-	<-
30 – F#1	Scratch Pull	<-	<-	<-
31 – G1	Sticks	<-	<-	<-
32 – G#1	Square Click	<-	<-	<-
33 – A1	Metronome Click	<-	<-	<-
34 – A#1	Metronome Bell	<-	<-	<-
35 – B1	Acoustic Bass Drum	<-	Room Bass Drum 1	Rock Bass Drum 1
36 – C2	Standard 1 Bass Drum	Standard 2 Bass Drum	Room Bass Drum 2	Rock Bass Drum 2
37 – C#2	Side Stick	<-	<-	<-
38 – D2	Standard 1 Snare	Standard 2 Snare	Room Snare	Rock Snare
39 – D#2	Hand Clap	<-	<-	<-
40 – E2	Standard 1 Snare Rim	Standard 2 Snare Rim	Room Snare Rim	Rock Snare Rim
41 – F2	Standard 1 Tom 6	Standard 2 Tom 6	Room Tom 6	Rock Tom 6
42 – F#2	Standard 1 Hi-hat Close	Standard 2 Hi-hat Close	Room Hi-hat Close	Rock Hi-hat Close
43 – G2	Standard 1 Tom 5	Standard 2 Tom 5	Room Tom 5	Rock Tom 5
44 – G#2	Standard 1 Hi-hat Pedal	Standard 2 Hi-hat Pedal	Room Hi-hat Pedal	Rock Hi-hat Pedal
45 – A2	Standard 1 Tom 4	Standard 2 Tom 4	Room Tom 4	Rock Tom 4
46 – A#2	Standard 1 Hi-hat Open	Standard 2 Hi-hat Open	Room Hi-hat Open	Rock Hi-hat Open
47 – B2	Standard 1 Tom 3	Standard 2 Tom 3	Room Tom 3	Rock Tom 3
48 – C3	Standard 1 Tom 2	Standard 2 Tom 2	Room Tom 2	Rock Tom 2
49 – C#3	Standard 1 Crash 1	Standard 2 Crash 1	Room Crash 1	Rock Crash 1
50 – D3	Standard 1 Tom 1	Standard 2 Tom 1	Room Tom 1	Rock Tom 1
51 – D#3	Standard 1 Ride	Standard 2 Ride	Room Ride	Rock Ride
52 – E3	Chinese Cymbal 1	<-	<-	<-
53 – F3	Ride Bell	<-	Room Ride Bell	Rock Ride Bell
54 – F#3	Tambourine	<-	<-	<-
55 – G3	Splash Cymbal	<-	Room Splash Cymbal	Rock Splash Cymbal
56 – G#3	Standard 1 Cowbell	Standard 2 Cowbell	Room Cowbell	Rock Cowbell
57 – A3	Standard 1 Crash 2	Standard 2 Crash 2	Room Crash 2	Rock Crash 2
58 – A#3	Vibra-slap	<-	<-	<-
59 – B3	Ride Cymbal	<-	<-	<-
60 – C4	Hi Bongo	<-	<-	<-
61 – C#4	Low Bongo	<-	<-	<-
62 – D4	Mute Hi Conga	<-	<-	<-
63 – D#4	Open Hi Conga	<-	<-	<-
64 – E4	Low Conga	<-	<-	<-
65 – F4	High Timbale	<-	<-	<-
66 – F#4	Low Timbale	<-	<-	<-
67 – G4	High Agogo	<-	<-	<-
68 – G#4	Low Agogo	<-	<-	<-
69 – A4	Cabasa	<-	<-	<-
70 – A#4	Maracas	<-	<-	<-
71 – B4	Short Whistle	<-	<-	<-
72 – C5	Long Whistle	<-	<-	<-
73 – C#5	Short Guiro	<-	<-	<-
74 – D5	Long Guiro	<-	<-	<-
75 – D#5	Claves	<-	<-	<-
76 – E5	Hi Wood Block	<-	<-	<-
77 – F5	Low Wood Block	<-	<-	<-
78 – F#5	Mute Cuica	<-	<-	<-
79 – G5	Open Cuica	<-	<-	<-
80 – G#5	Mute Triangle	<-	<-	<-
81 – A5	Open Triangle	<-	<-	<-
82 – A#5	Shaker	<-	<-	<-
83 – B5	Jingle Bell	<-	<-	<-
84 – C6	Bell Tree	<-	<-	<-
85 – C#6	Castanets	<-	<-	<-
86 – D6	Mute Surdo	<-	<-	<-
87 – D#6	Open Surdo	<-	<-	<-

GM Drum Voice List

	Funk (bank 17)	Electronic (bank 24)	808 (bank 25)	House (bank 28)
27 – D#1	<-	<-	<-	<-
28 E1	<-	<-	<-	<-
29 – F1	<-	<-	<-	<-
30 – F#1	<-	<-	<-	<-
31 – G1	<-	<-	<-	<-
32 – G#1	<-	<-	<-	<-
33 – A1	<-	<-	<-	<-
34 – A#1	<-	<-	<-	<-
35 – B1	Funk Bass Drum 1	Electronic Bass Drum 1	808 Bass Drum 1	House Bass Drum 1
36 – C2	Funk Bass Drum 2	Electronic Bass Drum 2	808 Bass Drum 2	House Bass Drum 2
37 – C#2	<-	<-	<-	<-
38 – D2	Funk Snare	Electronic Snare	808 Snare	House Snare
39 – D#2	<-	<-	<-	House Hand Clap
40 – E2	Funk Snare Rim	Electronic Snare Rim	808 Snare Rim	House Snare Rim
41 – F2	Funk Tom 6	Electronic Tom 6	808 Tom 6	House Tom 6
42 – F#2	Funk Hi-hat Close	Electronic Hi-hat Close	808 Hi-hat Close	House Hi-hat Close
43 – G2	Funk Tom 5	Electronic Tom 5	808 Tom 5	House Tom 5
44 – G#2	Funk Hi-hat Pedal	Electronic Hi-hat Pedal	808 Hi-hat Pedal	House Hi-hat Pedal
45 – A2	Funk Tom 4	Electronic Tom 4	808 Tom 4	House Tom 4
46 – A#2	Funk Hi-hat Open	Electronic Hi-hat Open	808 Hi-hat Open	House Hi-hat Open
47 – B2	Funk Tom 3	Electronic Tom 3	808 Tom 3	House Tom 3
48 – C3	Funk Tom 2	Electronic Tom 2	808 Tom 2	House Tom 2
49 – C#3	Funk Crash 1	<-	808 Crash 1	<-
50 – D3	Funk Tom 1	Electronic Tom 1	808 Tom 1	House Tom 1
51 – D#3	Funk Ride	<-	<-	<-
52 – E3	<-	<-	<-	<-
53 – F3	<-	<-	<-	<-
54 – F#3	<-	<-	<-	<-
55 – G3	<-	<-	<-	<-
56 – G#3	<-	<-	<-	<-
57 – A3	Funk Crash 2	<-	808 Crash 2	<-
58 – A#3	<-	<-	<-	<-
59 – B3	<-	<-	<-	<-
60 – C4	<-	<-	<-	<-
61 – C#4	<-	<-	<-	<-
62 – D4	<-	<-	808 Mute Hi Conga	<-
63 – D#4	<-	<-	808 Open Hi Conga	<-
64 – E4	<-	<-	808 Low Conga	<-
65 – F4	<-	<-	<-	<-
66 – F#4	<-	<-	<-	<-
67 – G4	<-	<-	<-	<-
68 – G#4	<-	<-	<-	<-
69 – A4	<-	<-	<-	<-
70 – A#4	<-	<-	808 Maracas	<-
71 – B4	<-	<-	<-	<-
72 – C5	<-	<-	<-	<-
73 – C#5	<-	<-	<-	<-
74 – D5	<-	<-	<-	<-
75 – D#5	<-	<-	808 Claves	<-
76 – E5	<-	<-	<-	<-
77 – F5	<-	<-	<-	<-
78 – F#5	<-	<-	<-	<-
79 – G5	<-	<-	<-	<-
80 – G#5	<-	<-	<-	<-
81 – A5	<-	<-	<-	<-
82 – A#5	<-	<-	<-	<-
83 – B5	<-	<-	<-	<-
84 – C6	<-	<-	<-	<-
85 – C#6	<-	<-	<-	<-
86 – D6	<-	<-	<-	<-
87 – D#6	<-	<-	<-	<-

GM Drum Voice List

	Jazz (bank 32)	Brush (bank 40)	Orchestra (bank 48)
27 - D#1	<-	<-	Concert Hi-hat Close
28 - E1	<-	<-	Concert Hi-hat Pedal
29 - F1	<-	<-	Concert Hi-hat Open
30 - F#1	<-	<-	Concert Ride
31 - G1	<-	<-	<-
32 - G#1	<-	<-	<-
33 - A1	<-	<-	<-
34 - A#1	<-	<-	<-
35 - B1	Jazz Bass Drum 1	Brush Bass Drum 1	Concert Bass Drum 1
36 - C2	Jazz Bass Drum 2	Brush Bass Drum 2	Concert Bass Drum 2
37 - C#2	<-	<-	<-
38 - D2	Jazz Snare	Brush Snare	Concert Snare 1
39 - D#2	<-	<-	Castanets
40 - E2	Jazz Snare Rim	Brush Snare Rim	Concert Snare 2
41 - F2	Jazz Tom 6	Brush Tom 6	Timpani F
42 - F#2	Jazz Hi-hat Close	<-	Timpani F#
43 - G2	Jazz Tom 5	Brush Tom 5	Timpani G
44 - G#2	Jazz Hi-hat Pedal	<-	Timpani G#
45 - A2	Jazz Tom 4	Brush Tom 4	Timpani A
46 - A#2	Jazz Hi-hat Open	<-	Timpani A#
47 - B2	Jazz Tom 3	Brush Tom 3	Timpani B
48 - C3	Jazz Tom 2	Brush Tom 2	Timpani C
49 - C#3	<-	Brush Crash 1	Timpani C#
50 - D3	Jazz Tom 1	Brush Tom 1	Timpani D
51 - D#3	Jazz Ride	Brush Ride	Timpani D#
52 - E3	<-	<-	Timpani E
53 - F3	<-	<-	Timpani F
54 - F#3	<-	<-	<-
55 - G3	<-	<-	<-
56 - G#3	<-	<-	<-
57 - A3	Chinese Cymbal 2	Brush Crash 2	Concert Crash 1
58 - A#3	<-	<-	<-
59 - B3	<-	<-	Concert Crash 2
60 - C4	<-	<-	<-
61 - C#4	<-	<-	<-
62 - D4	<-	<-	<-
63 - D#4	<-	<-	<-
64 - E4	<-	<-	<-
65 - F4	<-	<-	<-
66 - F#4	<-	<-	<-
67 - G4	<-	<-	<-
68 - G#4	<-	<-	<-
69 - A4	<-	<-	<-
70 - A#4	<-	<-	<-
71 - B4	<-	<-	<-
72 - C5	<-	<-	<-
73 - C#5	<-	<-	<-
74 - D5	<-	<-	<-
75 - D#5	<-	<-	<-
76 - E5	<-	<-	<-
77 - F5	<-	<-	<-
78 - F#5	<-	<-	<-
79 - G5	<-	<-	<-
80 - G#5	<-	<-	<-
81 - A5	<-	<-	<-
82 - A#5	<-	<-	<-
83 - B5	<-	<-	<-
84 - C6	<-	<-	<-
85 - C#6	<-	<-	<-
86 - D6	<-	<-	<-
87 - D#6	<-	<-	<-

MIDI Implementation Chart

Function...	Transmitted	Remarks
Basic Default	10 ch	
Channel Changed	X	
Mode Default	X	
Mode Messages	X	
Mode Altered	*****	
Note Number: True voice	0 - 127 *****	
Velocity Note on	O9nH, V = 1-127	
Velocity Note off	X (9 nH V=0)	
After Key's	X	
Touch Channel's	X	
Pitch Bend	X	
Control 0	X	Bank Select
Change 1	X	Modulation
5	X	Portamento Time
6	X	Data Entry
7	X	Volume
10	X	Pan
11	X	Expression
64	X	Sustain Pedal
65	X	Portamento ON/OFF
66	X	Sostenuto Pedal
67	X	Soft Pedal
80	X	Reverb Program
81	X	Chorus Program
91	X	Reverb Level
93	X	Chorus Level
120	X	All Sound OFF
121	X	Reset All Controller
123	X	All Notes OFF
Program Change : True #	X	
System Exclusive	X	
System : Song Position	X	
Common : Song Select	X	
: Tune	X	
System : Clock	O	
Real Time : Commands	O	Start And Stop Only
Aux : Local ON/OFF	X	
: All Notes OFF	X	
Messages : Active Sense	X	
: Reset	X	

O : YES X : NO



DD504D_G01

